

Presentation Cradle to Cradle



Circular Economy within Building Sector

Our Facts

**DREES &
SOMMER**



- 2.200 People
- 40 Locations
- 19 countries
- 45 years of experience
- > 30 expert disciplines

Management

Consulting

Engineering

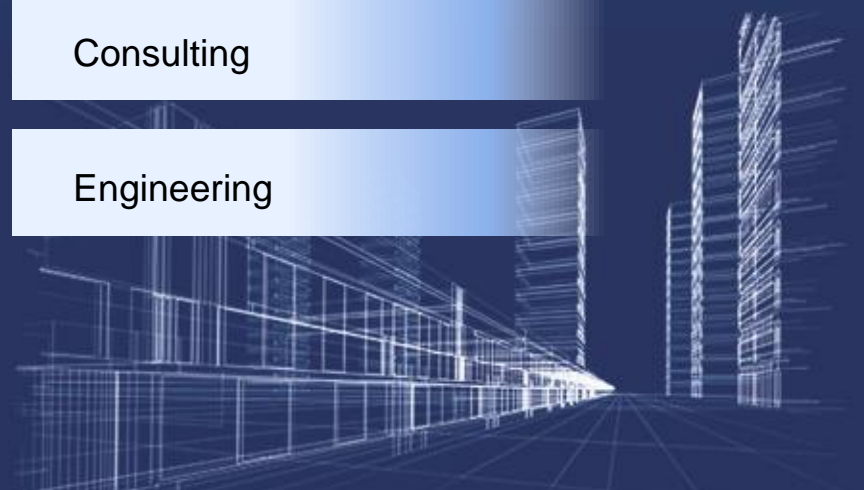

Reference projects (Excerpt)



Roche Bau, Basel



Cour de Justice Européenne,
Luxembourg



Cour des Comptes Européenne,
Luxembourg



Motel One, Paris



Centre Hospitalier du Luxembourg,
Luxembourg



Bâtiment Jean Monet 2, Luxembourg



CSSF, Luxembourg



Hochschule für Technik und
Wirtschaft, Saarbrücken



European Central Bank, Frankfurt

Status construction and real estate industry

Share of resource use worldwide

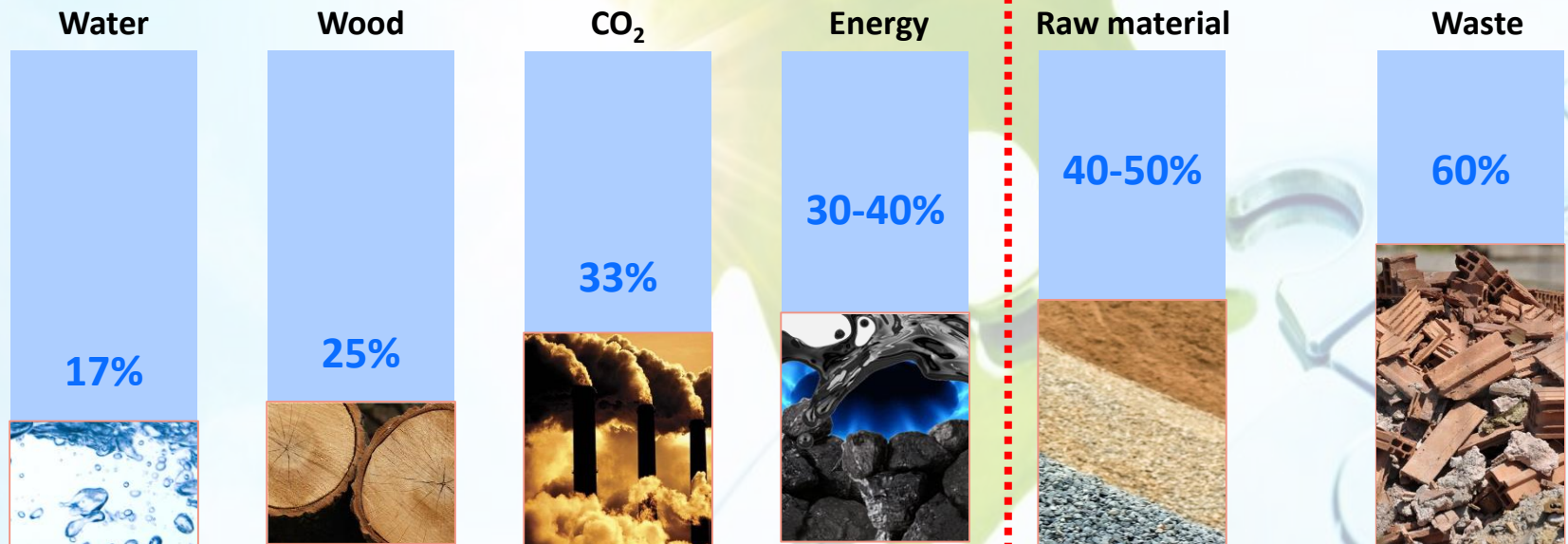

Quelle: UNEP, Statistisches Bundesamt

Holistic life-cycle assessment for buildings

Grey energy of building materials changes the parameters

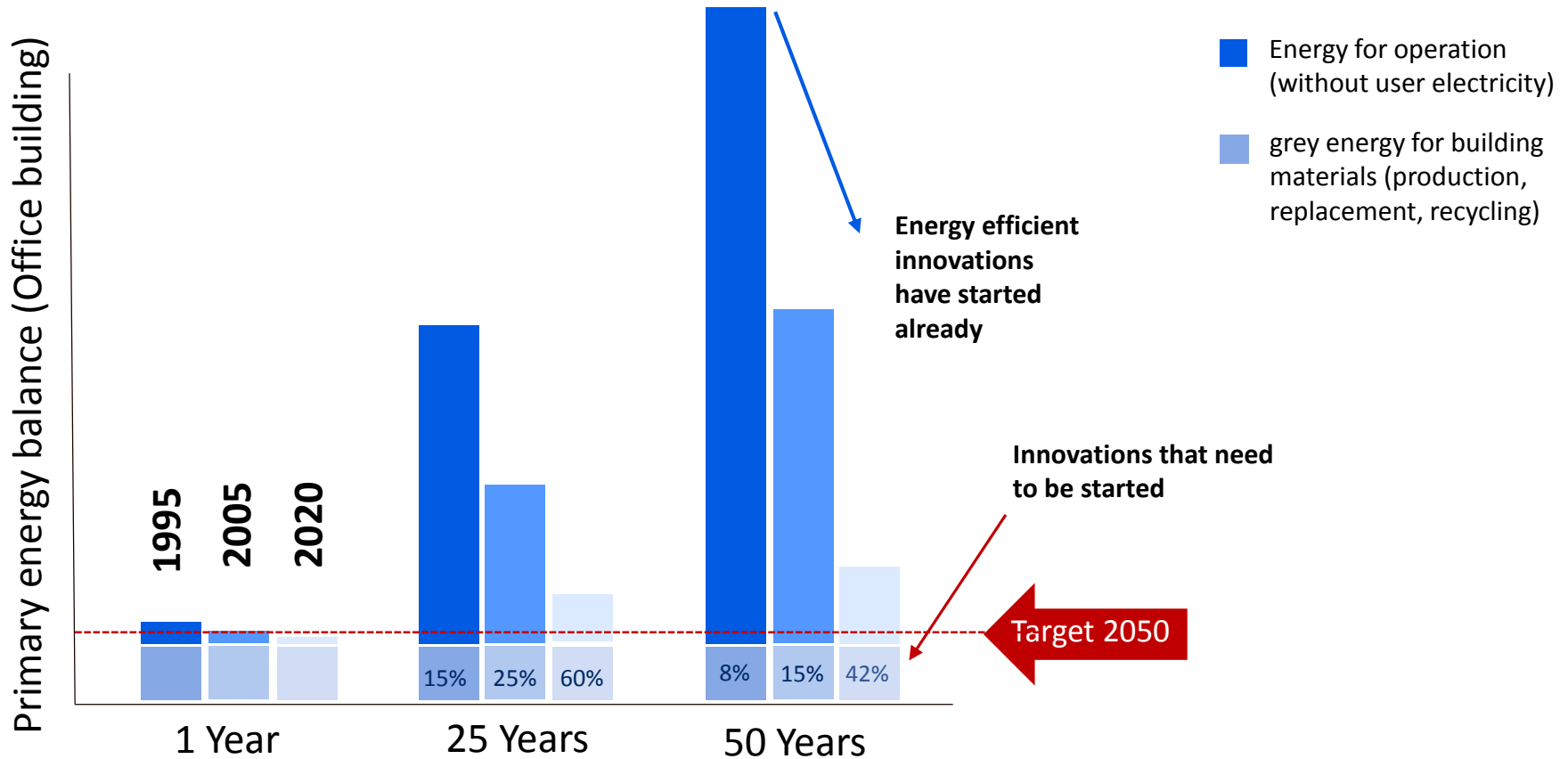

Energy efficiency

From energy efficiency path to Circular Economy

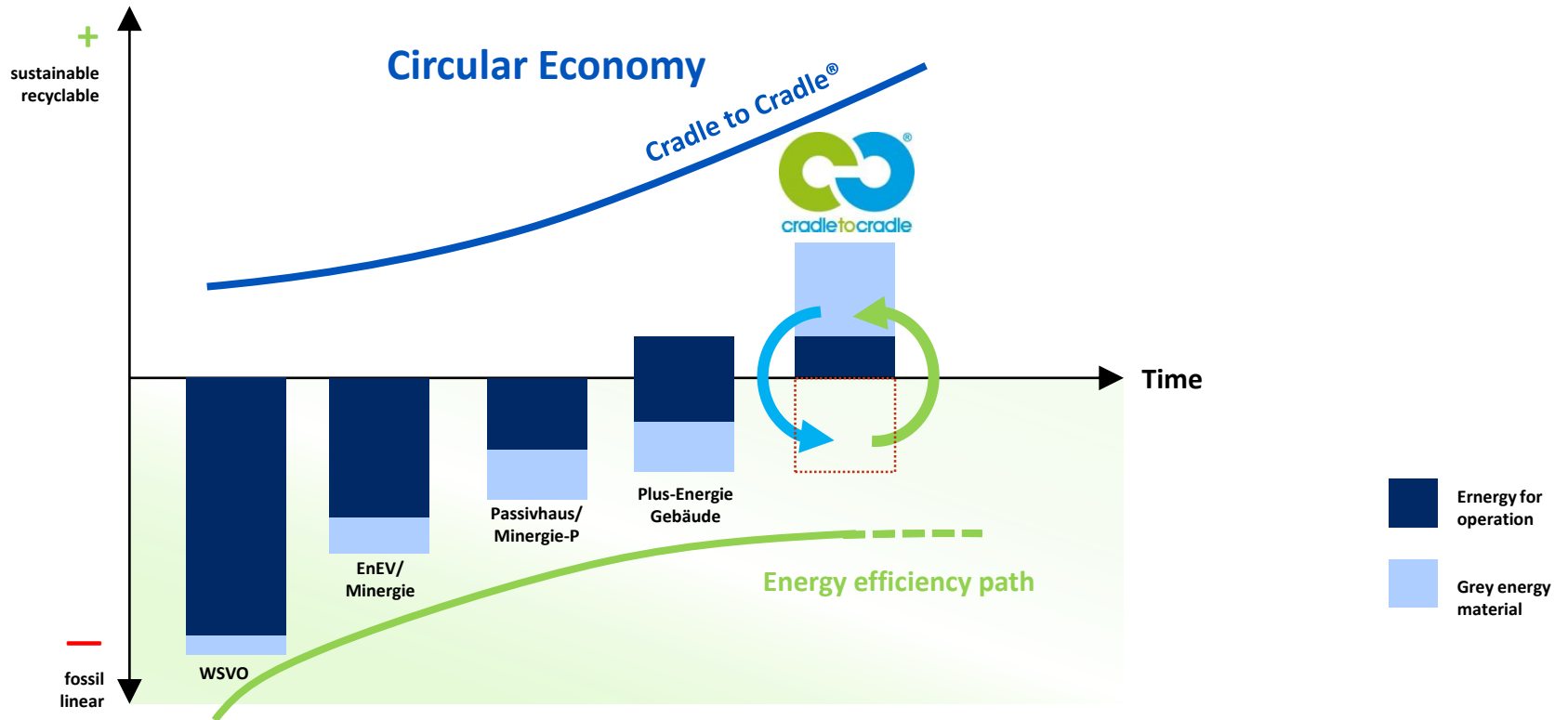

Recycling today in the building industry

Example of an outer wall

1. Paint
2. Mineral finish
3. Adhesive primer
4. Gypsum
5. Glass reinforcement mesh
6. EPS thermal insulation
7. Fastening plugs
8. Adhesive mortar
9. Sand-lime bricks
10. Mortar
11. Reinforcement steel
12. Copper fresh water pipes
13. Electrical cables
14. PVC sewer pipes
15. Telephone and IT cables
16. Plaster
17. Reinforcement grid
18. Wallpaper
19. Interior paint
- 20....



WDVS





Bild: www.gps-abbruch.de

20 mostly unseparable material layers → Downcycling!

Cradle to Cradle® by Drees & Sommer

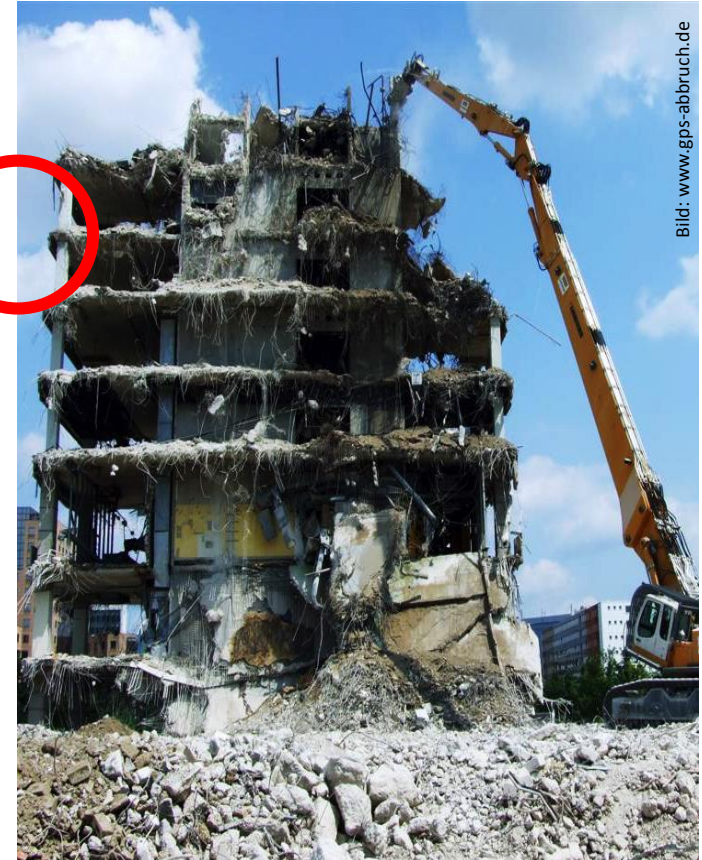
Range of services (examples)

| | | | | | |
|--------------|---|---|---|--|---|
| TARGET GROUP | Producers of construction products | owners, architects, planners | public sector, private sector | industrial sector, city marketing, city development | subsidy sponsors, EU, federal level, state level |
| SOLUTION | C2C-Produkt-Zertifizierung - optimisation - certification | Circular Engineering - C2C building biology - recycling conform construction - resource value appraisal, validation and activation - BIM integration | C2C-Consulting - C2C development of quarters - beneficial footprint elements - strategic C2C consulting | C2C-Business - new business models - circular economy concepts - urban governance | C2C-Research - all services |
| TOOLS | C2C Certificate  | Material Passport  | Studies, Concepts  | Calculations, Potential Analyses  | all tools  |

Detoxification of the supply chain

Knowing what is in it

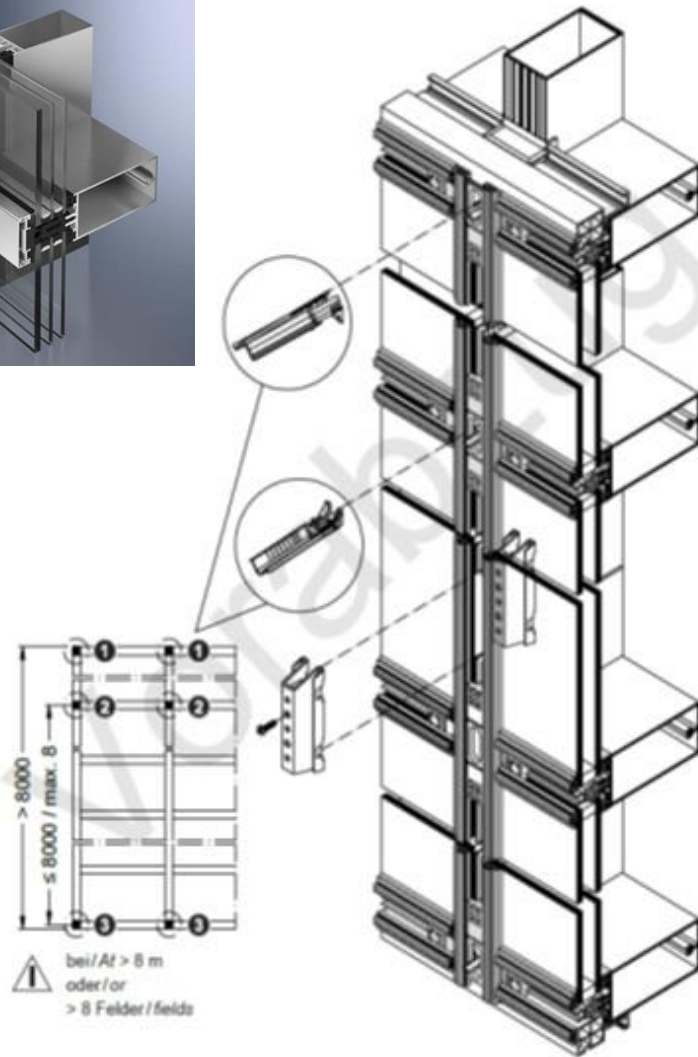
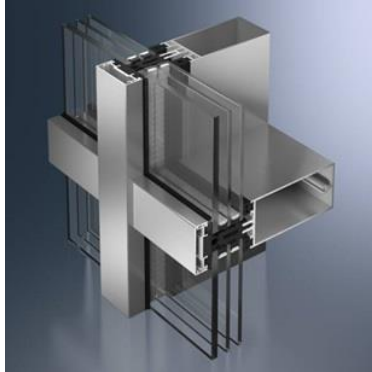

SCHÜCO

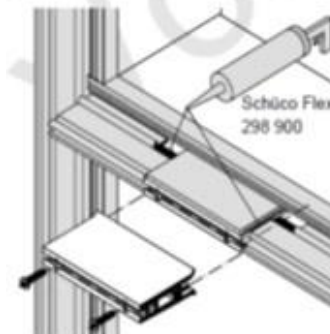
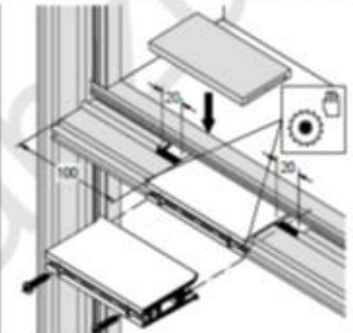
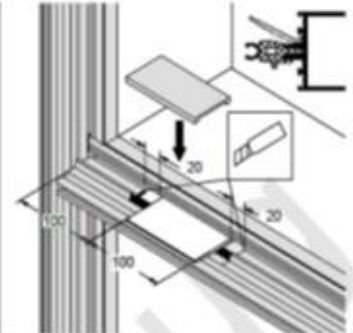
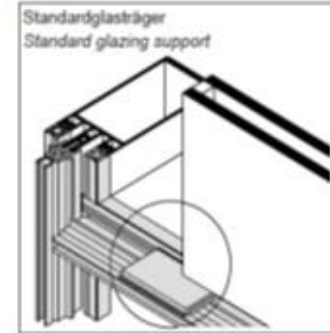

Circular Engineering

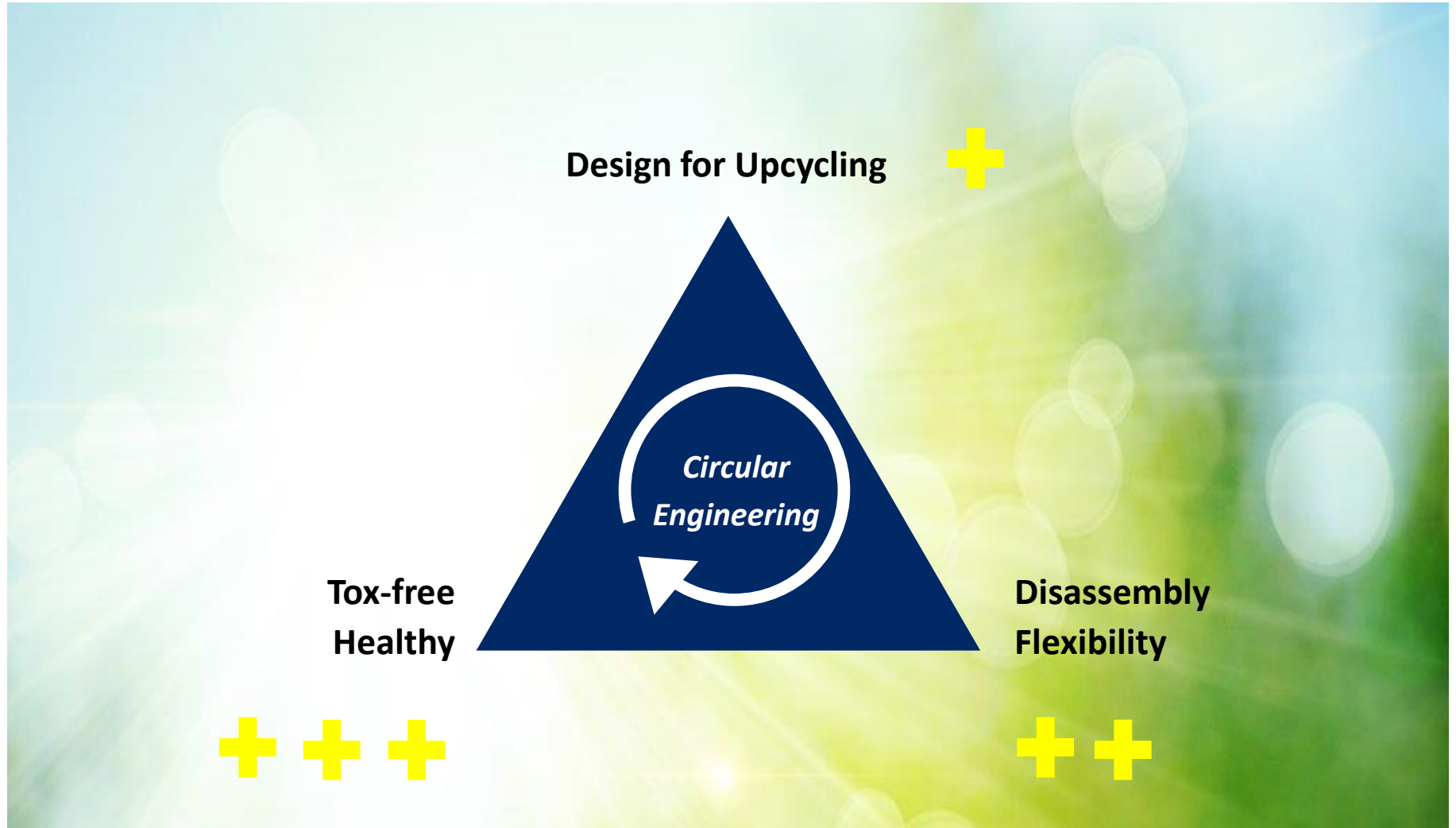

Construction example

Wall against soil: Perimeter insulation and sealing

Status Quo:



Problem:

- insoluble material compound
- no recycling possible
- toxic materials
- no access

Cradle to Cradle® Alternative:



Approach:

- Waterproof concrete vs. concrete + bitumen
- Wallbag with foam glass gravel vs. XPS (material made from scrap glass, 100% recyclable)

Solutions Facade

Modular building and separation of functions

Status Quo:

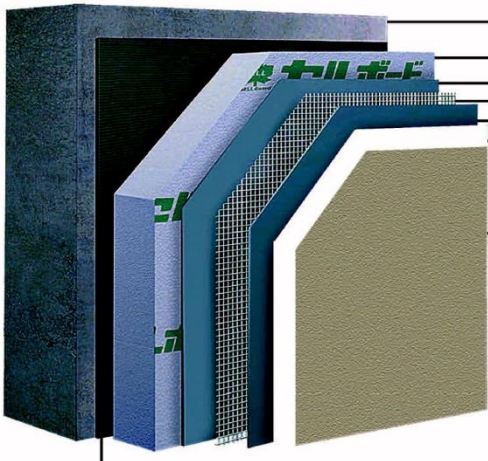

Problem:

- up to 20 unseparable material layers
- non recyclable toxic waste
- high pollution



Cradle to Cradle® Alternative:

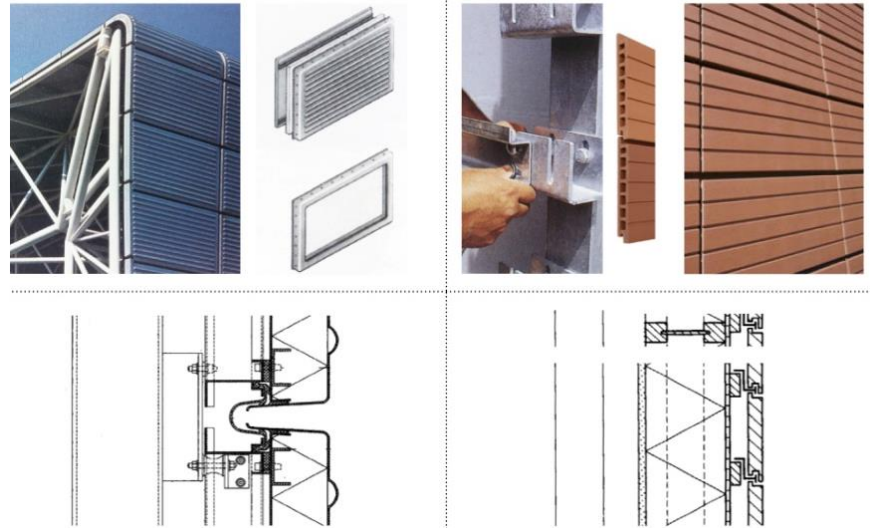

Approach:

- Demountable construction
- Separable material composites
- Separation of functions = flexibility in adaptation
- f.ex. Curtain facade, Element facade,...

Tool: Material Passport

Health, Disassembly, Circular

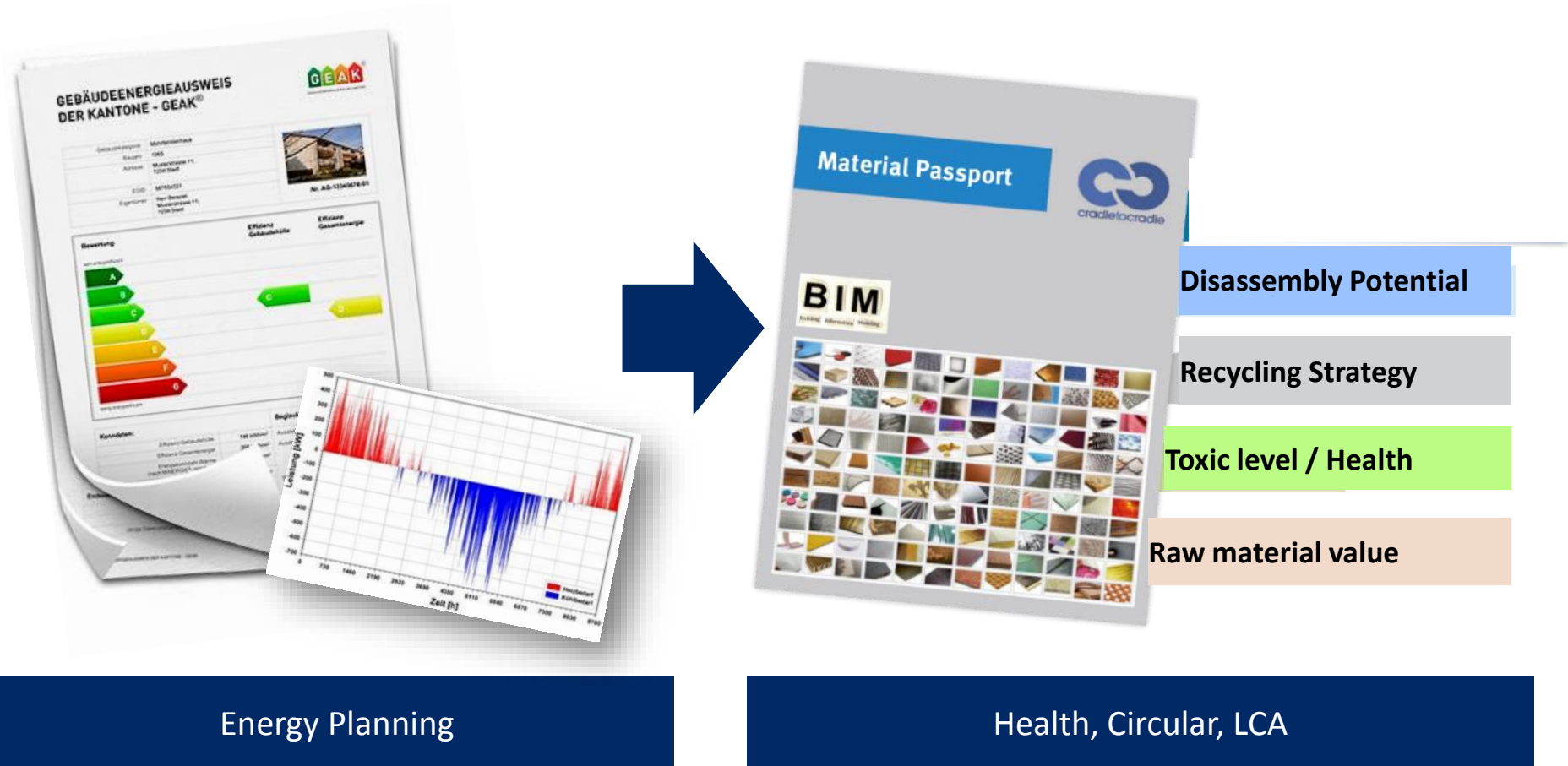

Material Passport for buildings

Consistent use of material-specific information

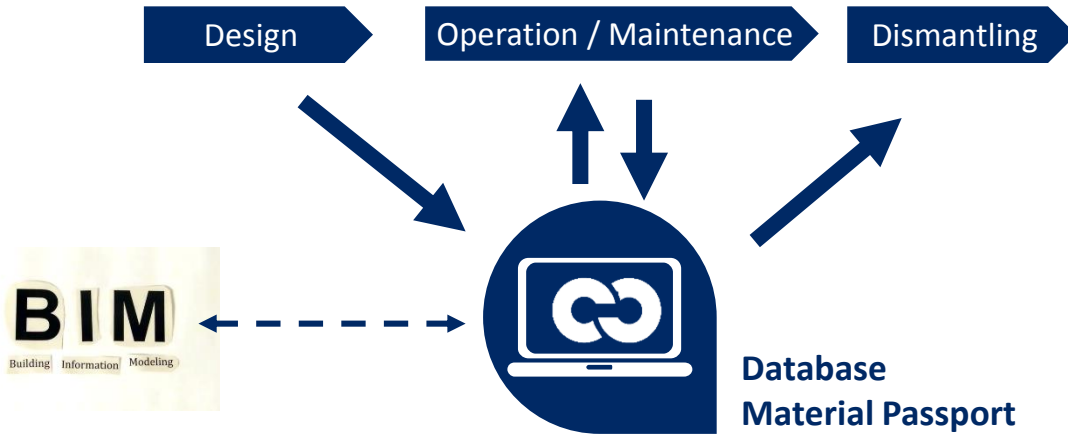

Material Passport
Extended digital construction elements catalogue with material information



For all construction materials used

- Building-ecological material declaration
- Material composition
- Mounting situation
- Separability proof
- Recycling concept
- Commodity stock

For the building:

- Modular and substitution concepts
- Disassembly structure

CONCLUDE Musterprojekt Drees & Sommer - Windows Internet Explorer

https://conclude.conclude.com/#/anest.jsp

Musterprojekt Drees & Sommer

Auswertung Projekt

Betrachtungsphase: Einzel / nF nGF
 Netto-Grundfläche (nGF): 18,125
 Betrachtungszeitraum (Jahre): 50

| | ADP | GWP | ODP | POCP | AP | EP | PEI n.e. | PEI em. | PEI ges. | PEI em. | PEI ges. |
|--|---------------------------|---------------------------|---------------------------|---------------------------|---------------------------|---------------------------|------------------|------------------|------------------|-----------------|-----------------|
| | [kg CO ₂ -Äq.] | [kg CO ₂ -Äq.] | [kg CO ₂ -Äq.] | [kg CO ₂ -Äq.] | [kg SO ₂ -Äq.] | [kg NO _x -Äq.] | [gpm ton/a] | [gpm ton/a] | [gpm ton/a] | [gpm ton/a] | [gpm ton/a] |
| Konstruktion | | | | | | | | | | | |
| Herstellung | 2.294E-02 | 3.914E-02 | 1.423E-07 | 1.218E-03 | 7.291E-03 | 9.243E-04 | 1.482E-01 | 2.775E-01 | 1.489E-01 | 1.88E-01 | 1.88E-01 |
| Fächeln- und zellbezogen (nF/nGF) | 4.587E-04 | 7.823E-02 | 2.850E-09 | 2.431E-05 | 1.450E-04 | 1.849E-02 | 2.923E-01 | 5.540E-03 | 2.075E-01 | 1.88E-01 | 1.88E-01 |
| Zuschlagsfaktor (R/nF) | 1.1 | 5.048E-04 | 8.611E-02 | 3.133E-09 | 2.875E-05 | 1.595E-04 | 2.034E-02 | 3.218E-01 | 6.094E-03 | 3.277E-01 | 1.88E-01 |
| Lebenszyklisches Sachverhaltverfahren | | | | | | | | | | | |
| Einbau | 1.492E-02 | 1.875E-02 | 4.322E-08 | 7.266E-04 | 2.907E-03 | 3.681E-04 | 9.956E-02 | 9.177E-02 | 9.147E-02 | 1.00E-01 | 1.00E-01 |
| Fächeln- und zellbezogen (E/nF) | 2.894E-04 | 3.749E-02 | 8.644E-10 | 1.453E-05 | 5.814E-05 | 7.322E-09 | 1.811E-01 | 1.835E-03 | 1.826E-01 | 1.00E-01 | 1.00E-01 |
| Zuschlagsfaktor (R/nF) | 1.1 | 3.282E-04 | 4.124E-02 | 9.558E-10 | 1.999E-05 | 6.395E-05 | 8.054E-09 | 1.992E-01 | 2.018E-03 | 2.012E-01 | 1.00E-01 |
| Lebenszyklisches Sachverhaltverfahren | | | | | | | | | | | |
| Rückbau | -1.441E-03 | 1.010E-02 | -2.246E-08 | 8.842E-05 | 1.233E-03 | 1.954E-04 | -1.981E-02 | -2.818E-02 | -1.036E-02 | -2.59E-02 | -2.59E-02 |
| Fächeln- und zellbezogen (R/nF) | -2.882E-05 | 2.018E-02 | -4.431E-10 | 1.728E-09 | 2.471E-05 | 3.989E-09 | -2.121E-02 | -8.638E-04 | -2.177E-02 | 2.59E-02 | 2.59E-02 |
| Zuschlagsfaktor (R/nF) | 1.1 | -3.170E-05 | 2.221E-02 | -4.874E-10 | 1.901E-09 | 2.710E-05 | 4.369E-09 | -2.333E-02 | -8.202E-04 | -2.395E-02 | 2.59E-02 |
| Lebenszyklisches Sachverhaltverfahren | | | | | | | | | | | |
| Konstruktion Gesamt (H + E) - (R) | 8.012E-04 | 1.496E-01 | 5.988E-09 | 4.463E-05 | 2.607E-04 | 3.276E-06 | 4.876E-01 | 7.493E-03 | 6.066E-01 | 1.48E-01 | 1.48E-01 |
| Nutzung | | | | | | | | | | | |
| Nutzung Strom | 3.645E-02 | 6.850E-03 | 1.872E-09 | 7.203E-07 | 1.016E-05 | 9.219E-07 | 1.158E-01 | 1.476E-02 | 1.304E-01 | 11.34E-01 | 11.34E-01 |
| Nutzung Wärme | 2.058E-02 | 3.215E-03 | 6.222E-12 | 9.888E-07 | 3.954E-06 | 3.848E-07 | 4.303E-02 | 3.248E-09 | 4.307E-02 | 0.93E-01 | 0.93E-01 |
| Nutzung Gesamt (St + W) | 5.703E-02 | 1.007E-02 | 1.875E-09 | 1.833E-06 | 1.414E-05 | 1.307E-06 | 1.588E-01 | 1.462E-02 | 1.734E-01 | 8.66E-01 | 8.66E-01 |
| Zuschlagsfaktor (St + W/nF) | 1.1 | 1.791E-02 | 2.788E-09 | 1.893E-06 | 2.648E-05 | 2.397E-06 | 3.866E-01 | 3.842E-02 | 3.999E-01 | 11.34E-01 | 11.34E-01 |
| Lebenszyklisches Sachverhaltverfahren | | | | | | | | | | | |
| Gesamtgebäude (H + N) | 8.824E-04 | 1.774E-01 | 7.488E-09 | 4.766E-05 | 2.933E-04 | 3.646E-05 | 9.866E-01 | 1.077E-02 | 1.017E-01 | 5.87E-01 | 5.87E-01 |
| Gesamt | 9.629E-04 | 1.774E-01 | 7.488E-09 | 4.766E-05 | 2.933E-04 | 3.646E-05 | 9.866E-01 | 1.077E-02 | 1.017E-01 | 5.87E-01 | 5.87E-01 |

New C2C - Building RAG, Essen



Solar Pergola



Material
Passport

Urban
Gardening

Roof for
People

Geothermal
Energy

Healthy Materials
RC-Concrete
Zero-Waste-Facade
...

Project with Market – Mainstream – Budget!

References

C2C-inspired buildings with Circular Engineering services by Drees & Sommer

Carmen Würth Forum, Künzelsau



HQ IOC, Lausanne



BMW, FIZ, München



Roche Bau 2, Basel



Cradle to Cradle Industrial Park

City of Bielefeld



C2C BIZZ
cradle to cradle in business sites

Sind „Cradle to Cradle“ inspirierte Gewerbegebiete ein Modell für die Zukunft?

Abschlussveranstaltung des EU-Projekt C2C-BIZZ in Bielefeld

Mittwoch, 15. April 2015
GOLDBECK GmbH, Bielefeld
17:00 Uhr

Bielefeld **WEGE**



City of Bielefeld
C2C study industrial park



Masterplan

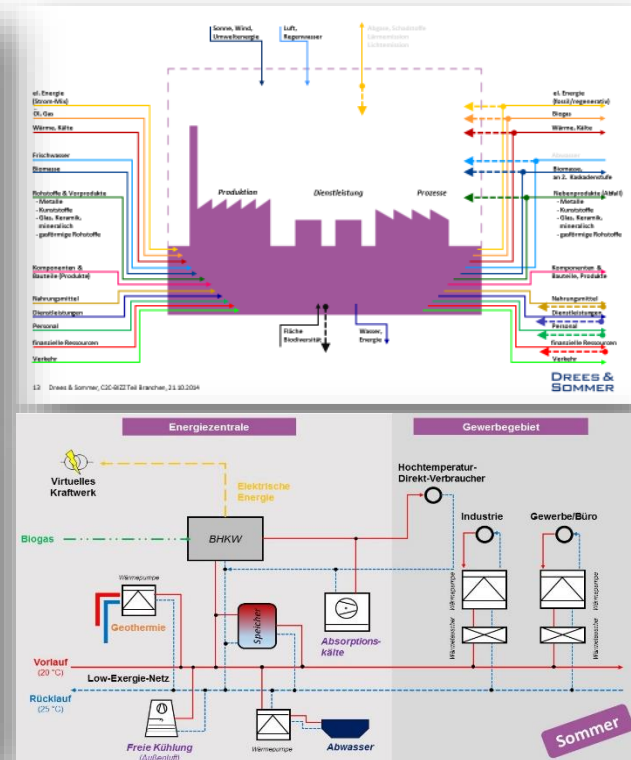

Studies regarding sector mix
Transfer Mediasien
Bidirektionales Low Exergie Netz

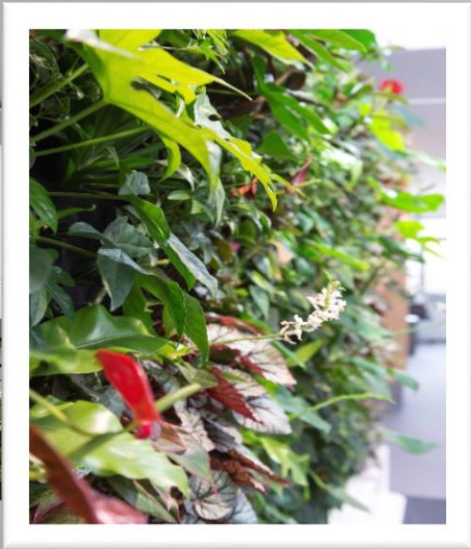

Activate raw material values

Positive performance

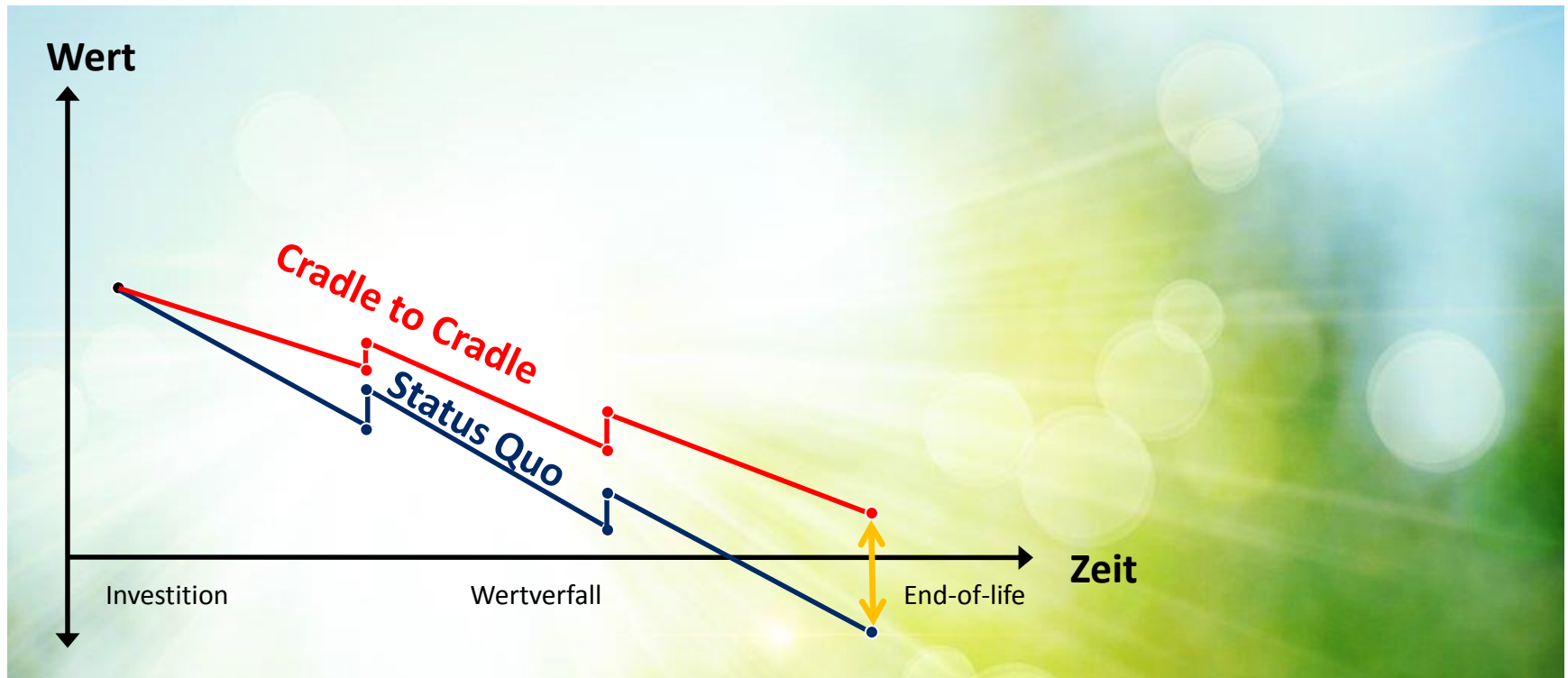

Building for the Circular Economy

Summary

Healthy & inspiring

- Tox-free
- Building-ecological materials
- Healthy
- Inspiring
- Increasing productivity



Building as raw materials stock & power house

- Recyclable building and infrastructure
- Local energy production
- Material cycles for all utilities like heat, cold, electricity, water, waste, industrial raw materials, ...

Added-value for society

- Active roll in society
- Urban Farming, air cleaning
- Good public perception and image

Flexible & convertible

- Adaptable infrastructure
- Convertible utilisation concepts
- Demountable, modular

Your innovative partner for

**CONSULTING
PLANNING
CONSTRUCTION
OPERATION**



**DREES &
SOMMER**

inspired by Cradle to Cradle®